

TECHNICAL BULLETIN

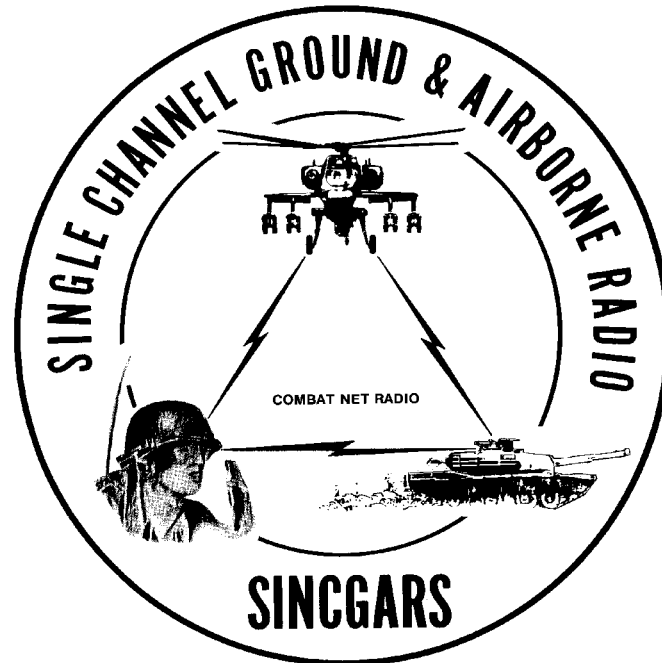

**INSTALLATION INSTRUCTIONS FOR
INSTALLATION KIT,
ELECTRONIC EQUIPMENT, MK-2914/VRC
(NSN 5895-01-486-6044) (EIC: N/A)
TO PERMIT INSTALLATION OF RADIO SETS
AN/VRC-91 SERIES AND AN/VRC-92 SERIES
IN A
FIGHTING VEHICLE, BFIST**

Approved for public release; distribution is unlimited.

HEADQUARTERS, DEPARTMENT OF THE ARMY

1 JANUARY 2004

TB 11-5820-890-20-115

INSERT LATEST CHANGED PAGES/WORK PACKAGES. DESTROY SUPERSEDED DATA.

LIST OF EFFECTIVE PAGES/WORK PACKAGES

NOTE: The portion of text affected by the changes is indicated by a vertical line in the outer margin of the page. Changes to illustrations are indicated by a vertical line adjacent to the title.

Date of issue for the original manual and changed pages/work packages are:

Original: 01 January 2004

TOTAL NUMBER OF PAGES IS 50, CONSISTING OF THE FOLLOWING:

Page/WP No.	*Change No.	Page/WP No.	*Change No.
Front Cover/blank	0		
A/(B blank)	0		
i/ii	0		
1 - 30	0		
A-1/(A-2 blank)	0		
DA Forms 2028	0		
Auth/blank	0		
Blank/Rear Cover	0		

*Zero in this column indicates an original page.

A/(B blank)

**INSTALLATION INSTRUCTIONS FOR
 INSTALLATION KIT
 ELECTRONIC EQUIPMENT MK-2914/VRC
 (NSN 5895-01-486-6044) (EIC: N/A)
 TO PERMIT INSTALLATION OF RADIO SET
 AN/VRC-91 SERIES AND AN/VRC-92 SERIES
 IN A
 FIGHTING VEHICLE, BFIST**

REPORTING OF ERRORS AND RECOMMENDING IMPROVEMENTS

You can help improve this manual. If you find any mistakes or if you know of a way to improve the procedures, please let us know. Mail your letter or DA Form 2028 (Recommended Changes to Publications and Blank Forms) direct to: Commander, US Army Communications-Electronics Command Fort Monmouth, ATTN: AMSEL-LC-LEO-D-CS-CFO, Fort Monmouth, NJ 07703-5006. The Fax number is 732-532-1413, DSN 992-1413. You may also e-mail your recommendation to: AMSEL-LC-LEO-PUBS-CHG@cecom3.monmouth.army.mil

In either case, a reply will be furnished direct to you.

TABLE OF CONTENTS

Subject	Section	Page
General Information.....	0.	1
Purpose of Installation.....	1.	3
End Item or System to be Modified.....	2.	3
Application Times.....	3.	3
Time for Completion of Installation.....	3.1	3
Time for Installation of One Assembly or Component.....	3.2	3
Preparation for Installation.....	4.	3
Preparation of Work Area.....	4.1	3
Preparation of Vehicle.....	4.2	3
Preparation of Installation Kit.....	4.3	3
Contents of Installation Kit.....	4.4	4
Consumable Materials Required.....	4.5	6
Tools and Test, Measurement, and Diagnostic Equipment (TMDE) Required.....	4.6	6
Installation Procedures.....	5.	8
Installation of Antenna, Vehicular, AS-3916VRC (antenna).....	5.1	11
Installation of Antenna Base.....	5.1.1	11
Installation of Top Antenna Assembly.....	5.1.2	14
Installation of Mounting Base, Electrical Equipment MT-6352/VRC (mounting base).....	5.2	15
Installation of Cables.....	5.3	17
Installation of Mounting Base, Electrical Equipment MT-6353/VRC.....	5.4	22
Post-Installation and Checkout.....	5.5	24
Appendix A References.....		A-1

LIST OF ILLUSTRATIONS

Figure	Title	Page
4-1	MK-2914/VRC Illustrated Parts List	5
4-2	Illustrated Parts List for Table 4-2.....	6
5-1(1)	MK and Radio Installation: MK Equipment Locations-Turret	8
5-1(2)	MK and Radio Installation: MK Equipment Locations-Hull	9
5-1(3)	MK and Radio Installation: Radio Equipment Locations.....	10
5-2(1)	Antenna Base Installation: Locations A and B	12
5-2(2)	Antenna Base Installation: Locations C and D	13
5-3	Top Antenna Assembly Installation	14
5-4	Mounting Base Installation	16
5-5(1)	Cable Installation: Turret Doorway	18
5-5(2)	Cable Installation: Turret Interior	20
5-5(3)	Cable Installation: RF Cable Routing.....	21
5-6	MT-6353/VRC Mounting Base Installation	23
5-7(1)	Cable Diagram: For AN/VRC-91 Series.....	25
5-7(2)	Cable Diagram: For AN/VRC-92 Series.....	26

LIST OF TABLES

Table	Title	Page
3-1	Installation Times.....	3
4-1	Parts List for Installation Kit, Electronic Equipment MK-2914/VRC	4
4-2	Additional Items Required for Installation of Radio Set AN/VRC-92 Series.....	6
4.3	Consumable Materials Required	9
4.4	Tools and Test, Measurement, and Diagnostic Equipment (TMDE) Required.....	9

0. GENERAL INFORMATION.

0.1 SCOPE.

This technical bulletin (TB) provides installation instructions for Installation Kit, Electronic Equipment MK-2914/VRC, commonly referred to as the Mounting Kit (MK). This MK shall be installed into the following type of vehicle(s):

- Fighting Vehicle, BFIST

The MK is used for installation of radio set components at field locations. The information contained in this technical bulletin is the official authorization to perform the installation at the unit maintenance level.

NOTE

This TB is not an authorization for requisition or turn-in of vehicles. This TB does not establish quantity or types of vehicles assigned to units.

0.2 CONSOLIDATED INDEX OF ARMY PUBLICATIONS AND BLANK FORMS.

Refer to the latest issue of DA Pam 25-30 to determine whether there are new editions, changes, or additional publications pertaining to the equipment.

0.3 MAINTENANCE FORMS, RECORDS, AND REPORTS.

0.3.1 Reports of Maintenance and Unsatisfactory Equipment. Department of the Army forms and procedures used for equipment maintenance will be those prescribed by DA Pam 738-750, as contained in Maintenance Management Update. Air Force personnel will use AFR 66-1 for maintenance reporting and TO-00-35D54 for unsatisfactory equipment reporting. Navy personnel will report maintenance performed utilizing the Maintenance Data Collection Subsystem (MDCS) IAW OPNAVINST 4790.2, Vol 3 and unsatisfactory material/conditions (UR) IAW OPNAVINST 4790.2, Vol 2, chapter 17. Marine Corps maintains forms and procedures as prescribed by TM 4700-15/1.

0.3.2 Reporting of Item and Packaging Discrepancies. Fill out and forward SF 364 (Supply Discrepancy Report (SDR)) as prescribed in AR 735-11-2/DLAR 4140.55/SECNAVINST 4355.18/AFR 400-54/MCO 4430.3J.

0.3.3 Transportation Discrepancy Report (TDR) (SF 361). Fill out and forward Transportation Discrepancy Report (TDR) (SF 361) as prescribed in AR 55-38/NAVSUPINST 4610.33C/AFR 75-18/MCO P4610.19D/DLAR 4500.15.

0.4 DESTRUCTION OF ARMY ELECTRONICS MATERIEL.

Destruction of Army electronics materiel to prevent enemy use shall be in accordance with TM 750-244-2.

0.5 REPORTING EQUIPMENT IMPROVEMENT RECOMMENDATIONS (EIR).

0.5.1 Army. If your equipment needs improvement, let us know. Send us an EIR. You, the user, are the only one who can tell us what you don't like about your equipment. Let us know why you don't like the design or performance. Put it on an SF 368 (Product Quality Deficiency Report). Mail it to: Commander, US Army Communications-Electronics Command and Fort Monmouth, ATTN: AMSEL-LC-LEO-D-CS-CFO, Fort Monmouth, New Jersey 07703-5006. We'll send you a reply.

0.5.2 Air Force. Air Force personnel are encouraged to submit EIR's in accordance with AFR 900-4.

0.5.3 Navy. Navy personnel are encouraged to submit EIR's through their local Beneficial Suggestion Program.

0.5.4 Marine Corps. QDR shall be reported on SF 368 in accordance with MCO P4855.10, Product Quality Deficiency Report Manual. Submit to Commanding General, Marine Corps Logistics Base (Code 850), Albany, Georgia 31704-5000.

THIS PAGE INTENTIONALLY BLANK

1. PURPOSE OF INSTALLATION.

Installation Kit Electronic Equipment MK-2914/VRC (MK) prepares a Fighting Vehicle, BFIST for the installation of SINGARS Radio Sets AN/VRC-91 Series and AN/VRC-92 Series. See Section 5.4 for instructions to install Mounting Base MT-6353/VRC.

2. END ITEM OR SYSTEM TO BE MODIFIED.

Installation Kit Electronic Equipment MK-2914/VRC can be installed in Fighting Vehicle, BFIST.

3. APPLICATION TIMES.

3.1 Time for Completion of Installation. Using two people, a total of 3.5 work hours is required. Typical vehicle downtime is 4 hours.

3.2 Time for Installation of One Assembly or Component. Table 3-1 lists the time required to install one component. All times have been rounded off to the nearest half hour. The sum of these items will not reflect the typical vehicle downtime.

Table 3-1. Installation Times		
ITEM	SECTION	TIME
Antenna AS-3916/VRC	5.1	1.0
Mounting Base, Electrical Equipment MT-6352/VRC	5.3	1.5
Cables	5.5	1.0

4. PREPARATION FOR INSTALLATION.

4.1 Preparation of Work Area. Ensure that the site has adequate lighting and a power source.

4.2 Preparation of Vehicle. Inspect the vehicle for damage that could affect installation. Have any such damage repaired before installing MK.

4.2.1 Items to be Removed. Remove existing AN/VRC-12 radio family installation kit and harness. See TM 11-5820-401-20-1 (for radios without intercom systems) or TM 11-5820-401-20-2 (for radios with intercom systems).

4.2.2 Items to be Retained for Reuse. None.

4.3 Preparation of Installation Kit. To prepare MK, unpack, inspect and check inventory.

4.3.1 Precautions During Handling. Observe these steps to prevent equipment damage.

- Keep dust cover in place on connectors.
- Do not disassemble or modify parts in MK unless authorized to do so.
- Keep mounting hardware covered and protected until needed.
- When exposed to moisture, rain or salt water, keep all parts dry to prevent corrosion.

4.3.2 Unpack and Inspect Equipment.

4.3.2.1 Inspect Packaging for Evidence of Damage. Report discrepancies as stated in para 0.3.3.

4.3.2.2 Unpack and Inventory MK. Refer to section 4.4. Report discrepancies as stated in para 0.3.2.

4.3.2.3 Examine Each Item for Damage. Report discrepancies as stated in para 0.3.2.

4.4 Contents of Installation Kit

Refer to Table 4-1 and Figure 4-1 to identify and inventory MK parts.

Table 4-1. Parts List for Installation of Radio Set AN/VRC-91 Series and AN/VRC-92 Series

NSN	ITEM DESCRIPTION AND PART NUMBER	QUANTITY IN MK	SMR CODE	FIGURE, ITEM NO.
5985-01-353-4943	Antenna, Vehicular AS-3916VRC (A3207487-1)	4	PAOOFA	4-1, 2
5305-00-847-1159	Screw, Cap, Hexagon (3/8-16 x 1 3/4 in) MS35307-365	16	PAOZZA	
5310-00-913-8881	Nut, Hexagon (3/8-16 in) MS51971-3 (8 Not Used)	16	PAOZZA	4-1, 1
5310-00-061-1258	Washer, Lock, Internal/External-Toothed (3/8 in) MS45904-76 (16 Not Used)	32	PAOZZA	
5310-00-889-2527	Washer, Lock, Internal/External-Toothed (5/16 in) MS45904-72 (Not Used)	8	PAOZZA	4-1, 4
5306-00-225-9086	Bolt, Machine (5/16 -24 x 5/8 in) MS90726-31 (Not Used)	4	PAOZZA	
5330-01-205-2864	Gasket (Not Used)	4	PAOZZA	4-1, 3
4010-01-381-1521	Wire Rope Assembly (A3207523-1)	4	PAOZZA	
5975-01-188-8873	Mounting Base, Electrical Equipment MT- 6352/VRC (A3013367-1)	2	PAOOFA	4-1, 3
5306-00-225-9089	Bolt, Machine (5/16-24 x 1 in) MS90726-34	10	PAOZZA	
5310-00-889-2527	Washer Lock, Internal/External-Toothed (5/16 in) MS45904-72	20	PAOZZA	4-1, 3
5310-00-880-7746	Nut, Hexagon (5/16-24 in) MS51968-5	10	PAOZZA	
5995-01-219-1845	Cable Assembly, Power Electrical CX-13306/VRC (8 FT, 0 IN) (A3014043-4)	1	PAOZZA	4-1, 3
5995-01-219-7029	Cable Assembly, Radio Frequency, CG-3855/VRC (5 FT, 0 IN) (A3014031-2)	1	PAOZZA	
5995-01-219-7030	Cable Assembly, Radio Frequency, CG-3855/VRC (7 FT, 0 IN) (A30`4031-3)	1	PAOZZA	4-1, 3
5995-01-225-1662	Cable Assembly, Radio Frequency, CG-3855/VRC (12 FT, 0 IN) (A3014031-12)	1	PAOZZA	
5995-01-219-7035	Cable Assembly, Radio Frequency, CG-3855/VRC (18 FT, 0 IN) (A3014031-8)	2	PAOZZA	4-1, 3
5340-00-809-1490	Clamp, Loop (1/4-1/4 in) MS21333-98	4	PAOZZA	
5340-00-984-8540	Clamp, Loop (1/2-1/4 in) MS21333-102	1	PAOZZA	4-1, 3
5340-00-809-1494	Clamp, Loop (3/4-1/4 in) MS21333-105	2	PAOZZA	
5340-00-809-1500	Clamp, Loop (1-1/4 in) MS21333-107	1	PAOZZA	4-1, 3
5305-00-068-0500	Screw, Cap, Hexagon (1/4-20 x 1/2 in) MS90725-3	4	PAOZZA	
5305-00-984-6210	Screw, Machine, Pan-Head (No. 10-24 x 1/2 in) MS35206-263	4	PAOZZA	4-1, 3
5975-00-111-3208	Strap, Tiedown, Electrical Components MS3367-5- 9	25	PAOZZA	
5310-00-582-5965	Washer, Lock (1/4 in) MS35338-44	2	PAOZZA	4-1, 3
5310-00-048-3296	Washer, Lock (No. 10) MS35338-43	4	PAOZZA	

5310-00-889-2528	Washer, Lock, Internal/External Toothed (1/4 in) MS45904-68	4	PAOZZA	
------------------	--	---	--------	--

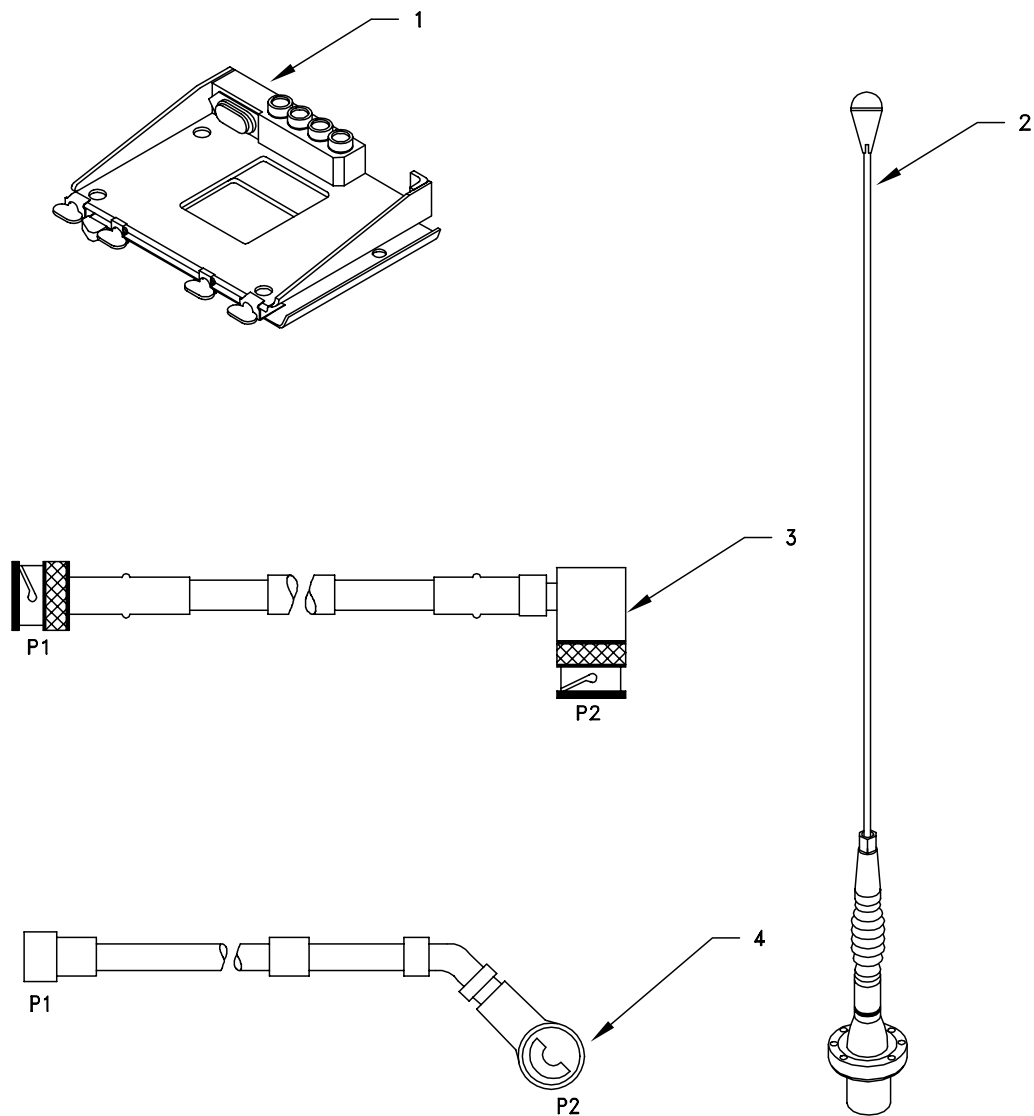

Figure 4-1. MK Illustrated Parts List

Table 4-2. Additional Items Required for Installation of Radio Set AN/VRC-92 Series

NSN	ITEM DESCRIPTION AND PART NUMBER	QUANTITY IN MK	SMR CODE	FIGURE, ITEM NO.
5975-01-235-1962	Mounting Base, Electrical Equipment MT-6353/VRC (A3014053-1)	1	PAOFHA	4-2, 1
5306-00-225-9089	Bolt, Machine (5/16-24 x 1 in) MS90726-34	4	PAOZZA	
5310-00-880-7746	Nut, Hexagon (5/16-24 in) MS51968-5	2	PAOZZA	
5310-00-889-2527	Washer, Lock, Internal/External-Toothed (5/16 in) MS45904-72	6	PAOZZA	
5310-00-081-4219	Washer, Flat (5/16 in) MS27183-12 (Not Used)	2	PAOZZA	
	Nut Strip (A3014064-1)	1	XBOZZA	4-2, 5
5975-00-111-3208	Strap, Tiedown, Electrical Components MS3367-5-9	12	PAOZZA	
5995-01-300-9324	Cable Assembly, Power, Electrical CX-13303/VRC (4 FT, 6 IN) (A3014040-9)	1	PAOZZA	4-2, 4
5995-01-222-4209	Cable Assembly, Special Purpose, Electrical CX-13291/VRC (3 FT, 0 IN) (A3014037-1)	1	PAOZZA	4-2, 2
5995-01-219-7025	Cable Assembly, Radio Frequency CG-3856/VRC (5 FT, 0 IN) (A3014032-3)	1	PAOZZA	4-2, 3

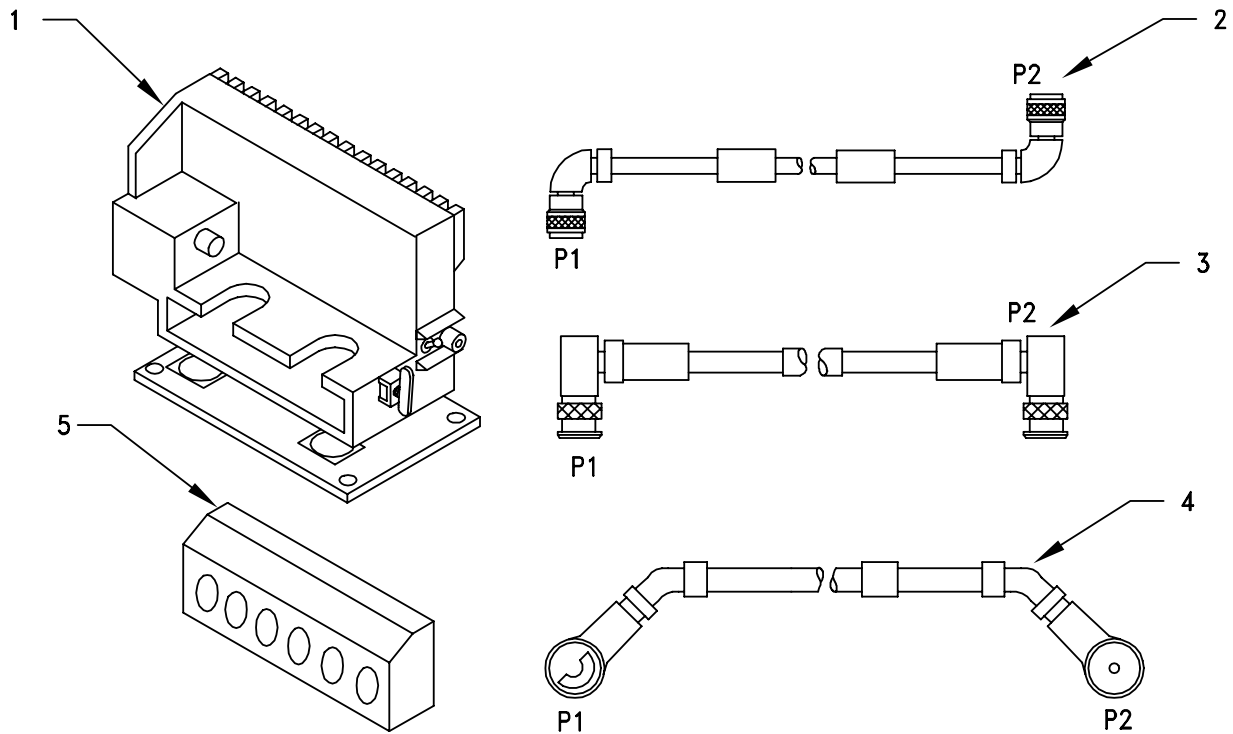

Figure 4-2. Illustrated Parts List for Table 4-2

4.3.3. Consumable Materials.

Table 4-3 lists materials required for installation but not supplied with the MK.

Table 4.3. Consumable Materials Required	
NSN	NOMENCLATURE
8040-01-331-7133	Adhesive-Sealant, Clear, RTV
6850-00-880-7616	Silicone Compound, MIL-S-8660
8030-00-292-1102	Conductive Anti-Seize Compound

4.4. Tools and Test, Measurement, and Diagnostic Equipment (TMDE) Required.

The following tools and TMDE are needed for installation.

Table 4.4. Tools and Test, Measurement, and Diagnostic Equipment (TMDE) Required		
NOMENCLATURE	NSN	QUANTITY
Radio Sets*		2
Frequency Hopping Multiplexer*		1
Electric Grinder (or equivalent)		1
Pocket Knife, Electrician's	5110-00-240-5943	1
Screwdriver, No. 2 Point Phillips, 4 in	5120-00-234-8913	1
Screwdriver, 1/4 in Flat blade, 4 in	5120-00-222-8852	1
Pliers, Round Nose	5120-00-240-6172	1
Pliers, Diagonal Cutting	5110-00-965-0974	1
Wrench, Open/Box:		
7/16 in	5120-00-228-9505	1
1/2 in	5120-00-228-9506	1
9/16 in	5120-00-228-9507	1
Handle, Socket Wrench:		
Socket		
7/16 in	5120-00-240-5364	1
1/2 in	5120-00-227-6703	1
9/16 in	5120-00-237-0977	1
9/16 in	5120-00-227-6704	1
Electric Drill	5130-00-889-8994	1
Drill Bit:		
11/32 in	5133-00-227-9664	1

* Use radio issued with your vehicle if available.

5. INSTALLATION PROCEDURES.

This section describes where and how to install MK items in the vehicle. When installing MK equipment, be sure to read and follow instructions and illustrations carefully. See Figure 5-1 for an overall view of where MK equipment, as well as radio components will be installed. See section 5.4 for instructions to install MT-6353/VRC mounting base.

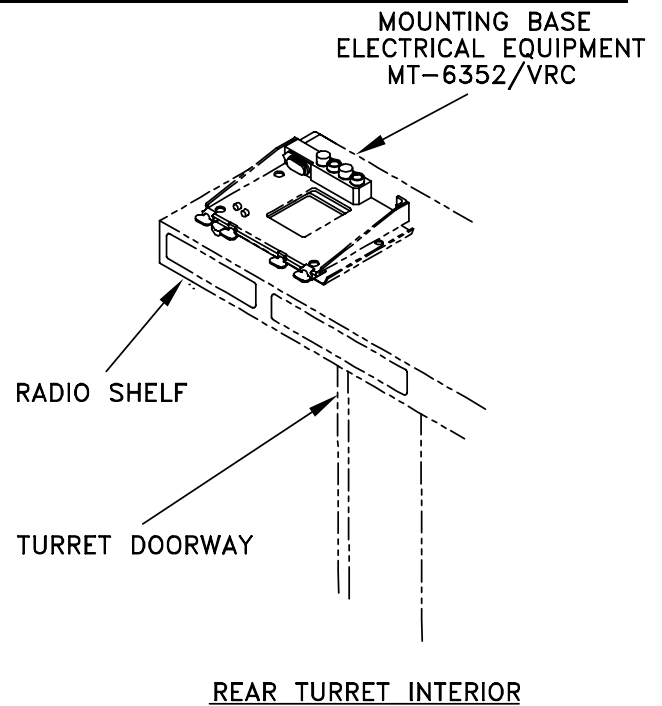
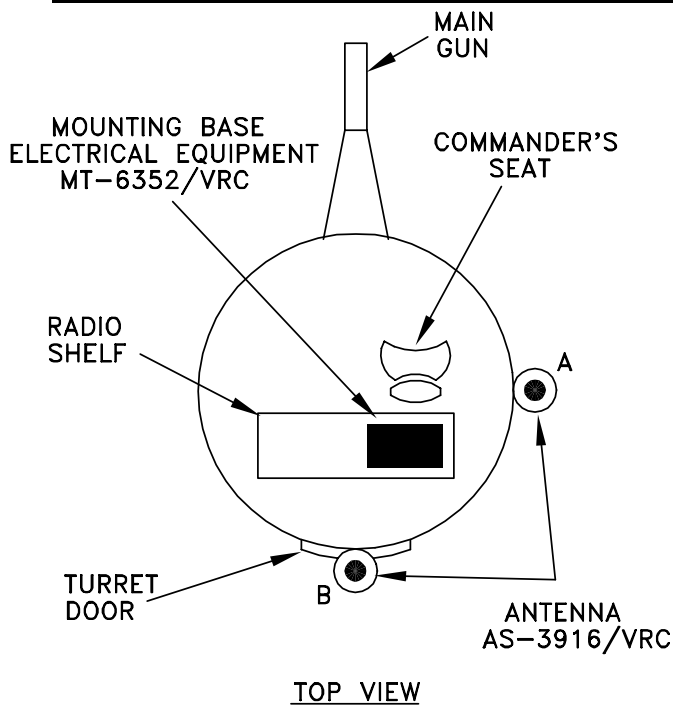
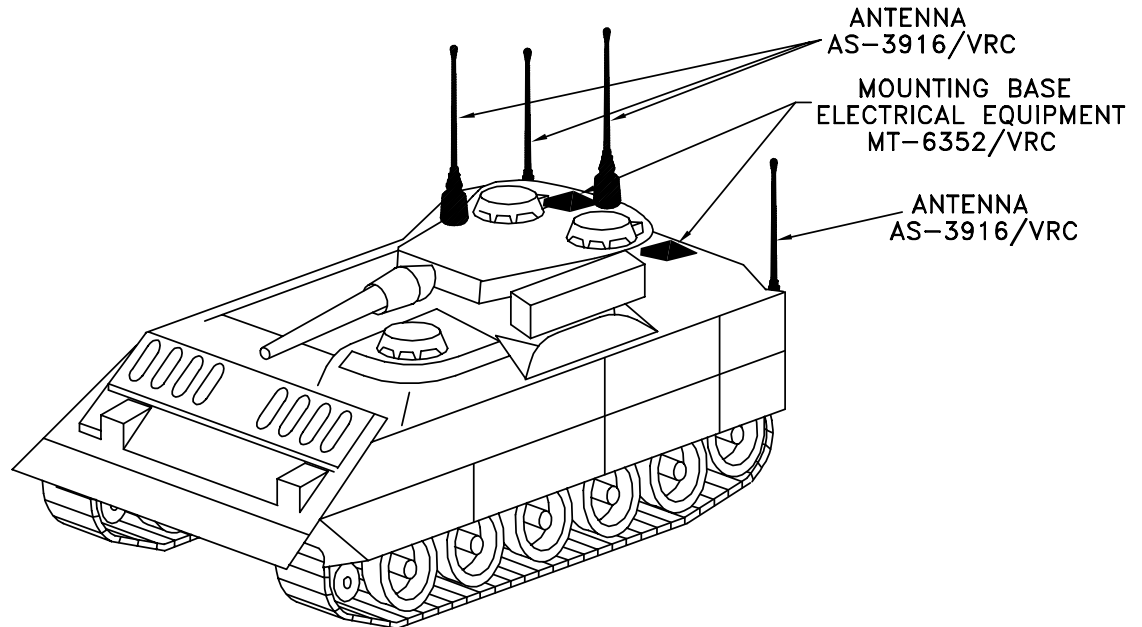

Figure 5-1 (1). MK and Radio Installation: MK Equipment Locations (Turret)

5. INSTALLATION PROCEDURES. Continued.

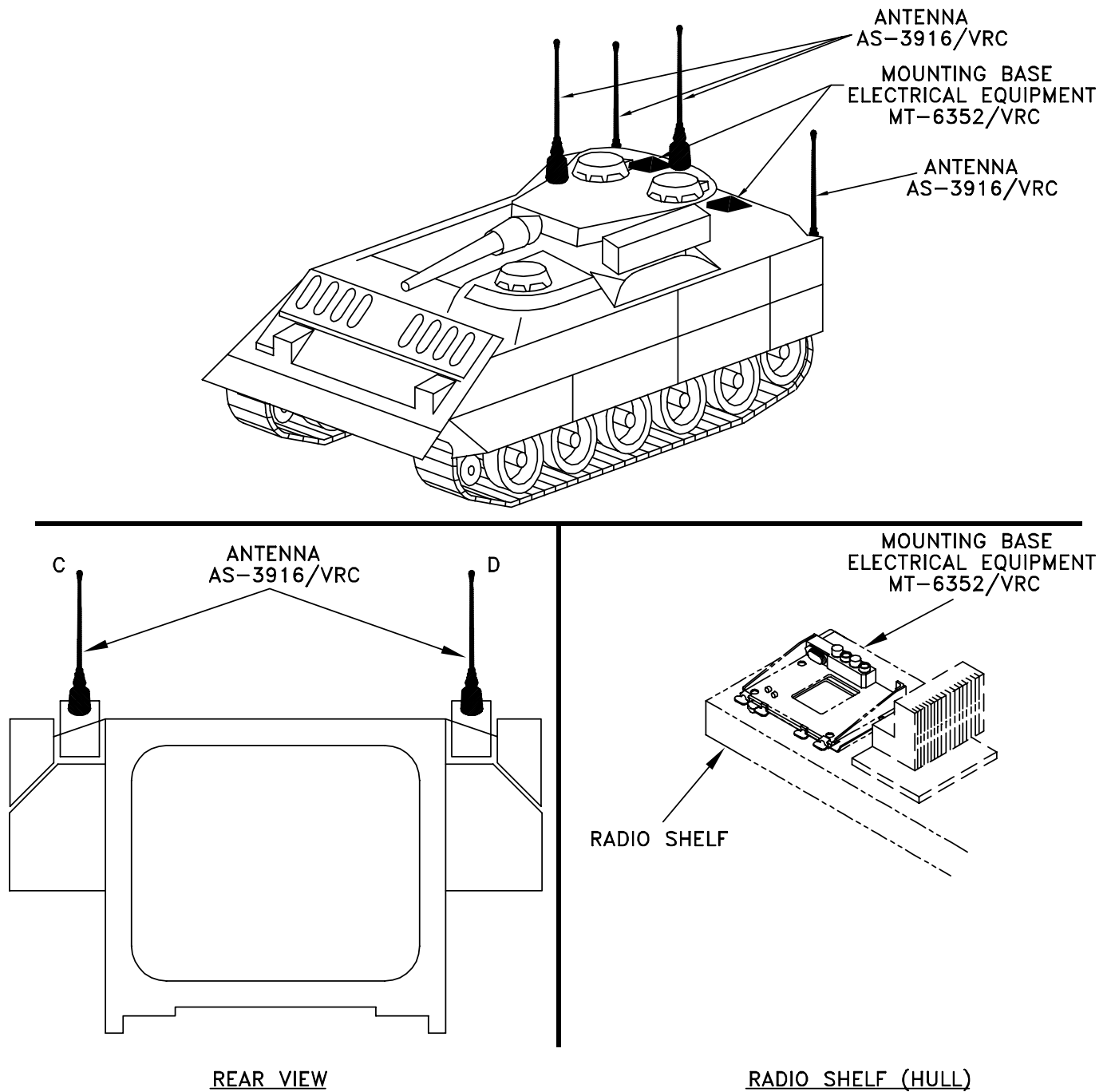
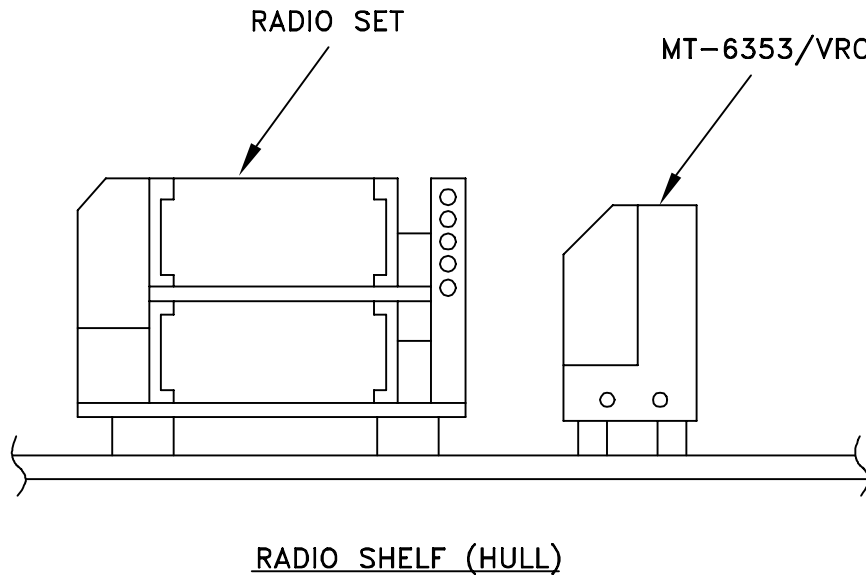

Figure 5-1 (2). MK and Radio Installation: MK Equipment Locations (Hull)

5. INSTALLATION PROCEDURES. Continued.

INSTALLATION
FOR
AN/VRC-92 SERIES



INSTALLATION
FOR
AN/VRC-91 SERIES

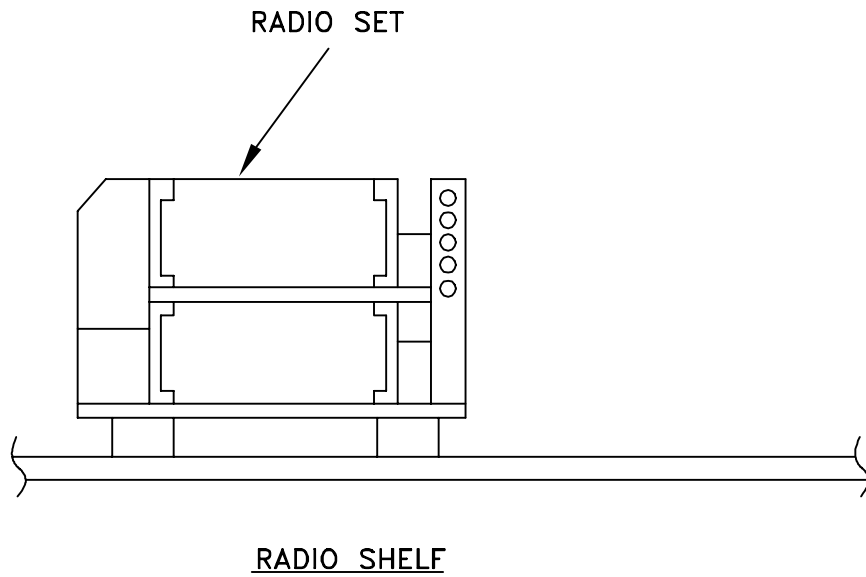

Figure 5-1 (3). MK and Radio Installation: Radio Equipment Locations

5.1 Installation of Antenna, Vehicular, AS-3916/VRC (antenna).

5.1.1 Installation of Antenna Base. Use the following procedures to install four antenna bases. See figure 5-1 (1) for locations. Remove ground strap from antenna base(s).

ITEM	ACTION	REMARKS
NOTE		
Apply a thin coat of adhesive-sealant to both sides of each internal/external-toothed (IET) washer during installation, and to the area of contact where IET washer is to be placed.		
a. Locations A and B.	See Figure 5-1 (1) for locations.	
b. Existing antenna ports.	Remove the paint (1" strip) for 360° centered around the four mounting holes. Clean the paint removed areas and apply a thin coat of conductive anti-seize compound.	Tools: Electric grinder or equivalent.
c. Antenna base (3).	Place on top of antenna port. Align holes with mounting holes.	
d. Four cap screws (1) and four internal/external toothed (IET) washers (2).	Install and secure to antenna base (3) and existing antenna port.	Tools: 9/16 in socket.
e. Cap screw (5), two internal/external toothed (IET) washers (4), and loop clamp (6).	Install (without securing) to existing boss.	Tools: 1/2 in socket.
f. Antenna base (3) and existing antenna port.	Apply a bead of adhesive-sealant/silicon compound 360° around the seam between antenna base (3) and existing antenna port.	
g. Locations C and D.	See Figure 5-1 (2) for locations.	
h. Existing antenna guards.	Remove the paint (1" strip) for 360° centered around the four mounting holes. Clean the paint removed areas and apply a thin coat of conductive anti-seize compound.	Tools: Electric grinder or equivalent.
i. Antenna base (1).	Place on top of antenna guard. Align holes with mounting holes.	
j. Four cap screws (2), eight internal/external toothed (IET) washers (3), and four nuts (4)	Install and secure to antenna base (1) and antenna guard.	Tools: 9/16 in socket and 9/16 in open/box wrench.
k. Antenna base (1) and existing antenna guard.	Apply a bead of adhesive-sealant/silicon compound 360° around the seam between antenna base (1) and existing antenna guard.	

5.1.1 Installation of Antenna Base. Continued

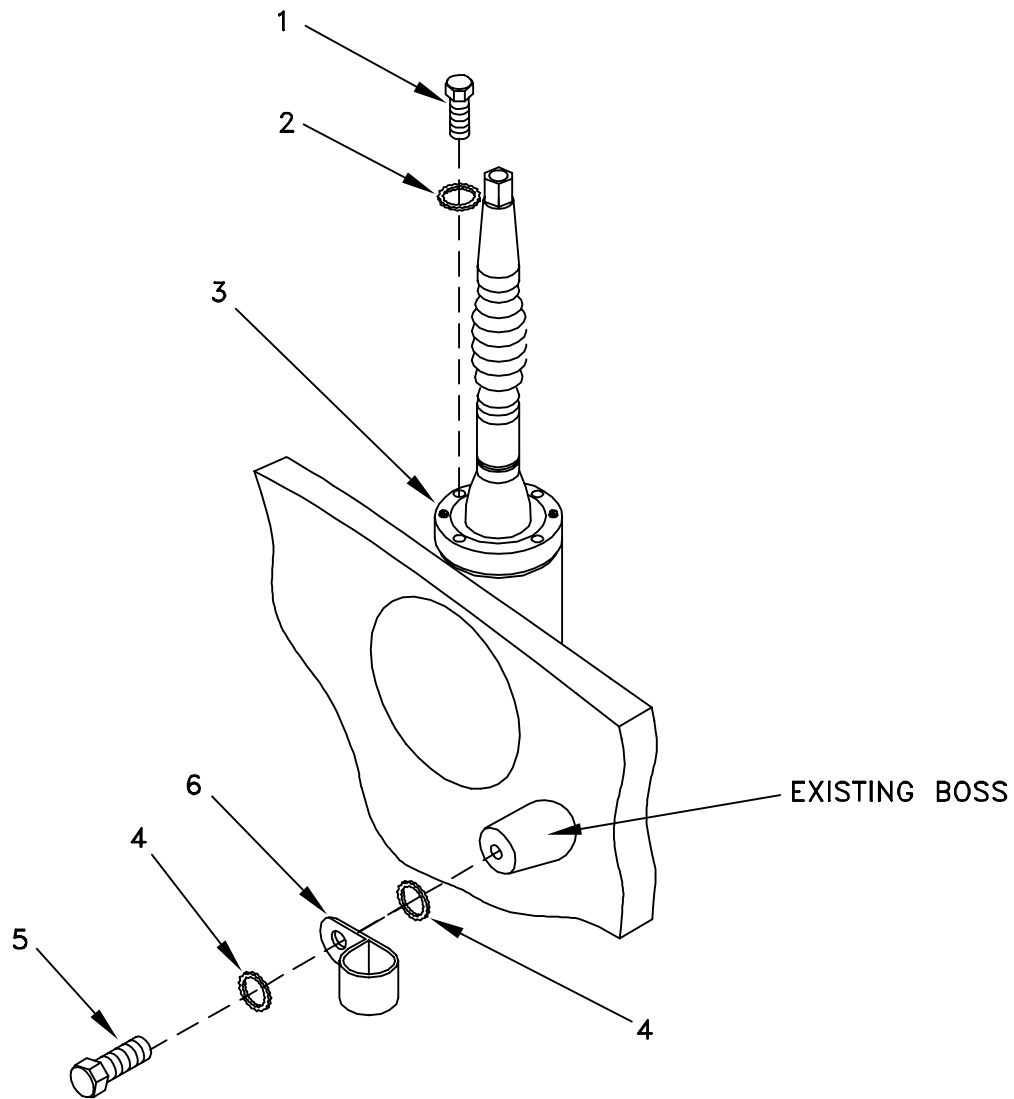

1. CAP SCREW (3/8-16 x 1 3/4 IN)
2. IET WASHER (3/8 IN)
3. ANTENNA BASE
4. IET WASHER (1/4 IN)
5. CAP SCREW (1/4-20 x 1/2 IN)
6. LOOP CLAMP (1/4-1/4 IN)

Figure 5-2 (1). Antenna Base Installation: Locations A and B

5.1.1 Installation of Antenna Base. Continued

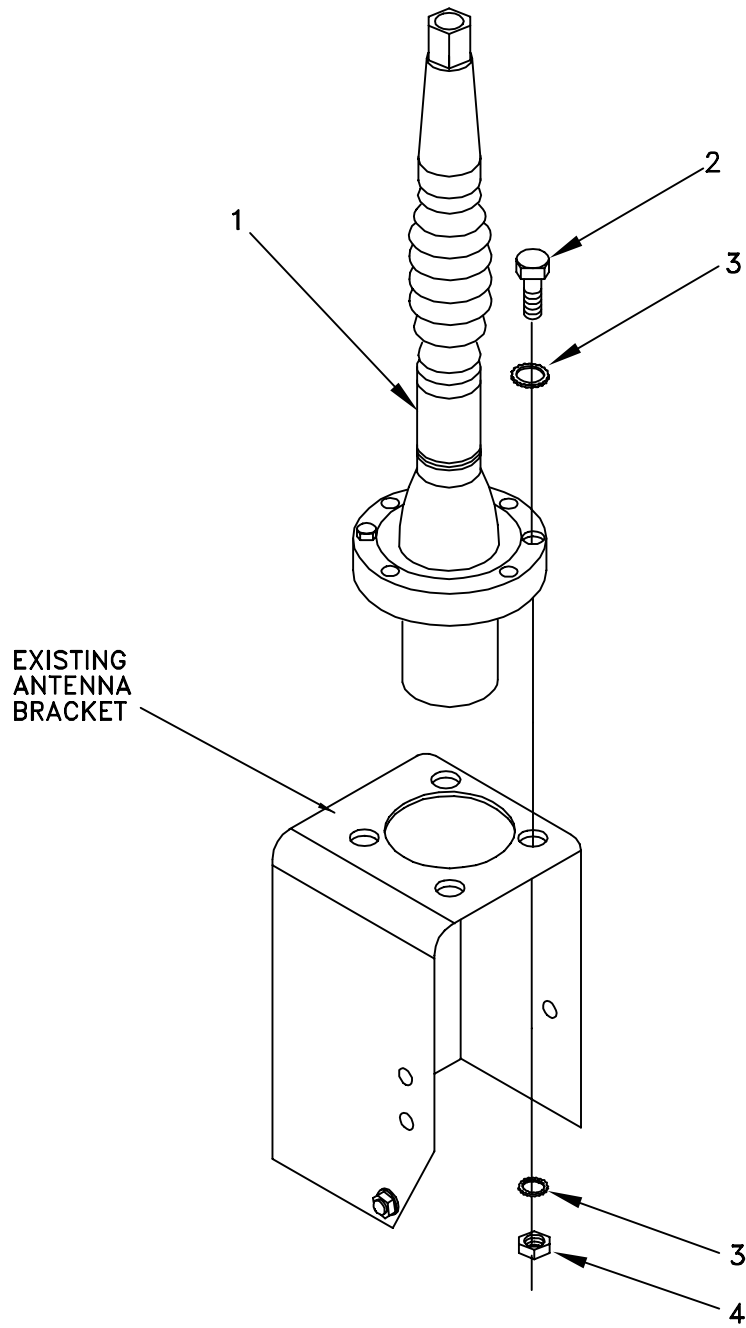

- 1. ANTENNA BASE
- 2. CAP SCREW (3/8-16 x 1 3/4 IN)
- 3. IET WASHER (3/8 IN)
- 4. NUT (3/8-16 IN)

Figure 5-2 (2). Antenna Base Installation: Locations C and D

5.1.2 Installation of Top Antenna Assembly. The top portion of the antenna consists of one element (with installed cap). Use the following procedure to install and tiedown all antennas.

ITEM	ACTION	REMARKS
------	--------	---------

- | | | |
|----------------------------|--|--|
| a. Antenna element (1). | Install and secure to antenna base (2). | |
| b. Wire rope assembly (3). | Attach clip to antenna element (1). Tie rope to vehicle to position antenna in desired location. See Figure 5-3, Detail A. | |

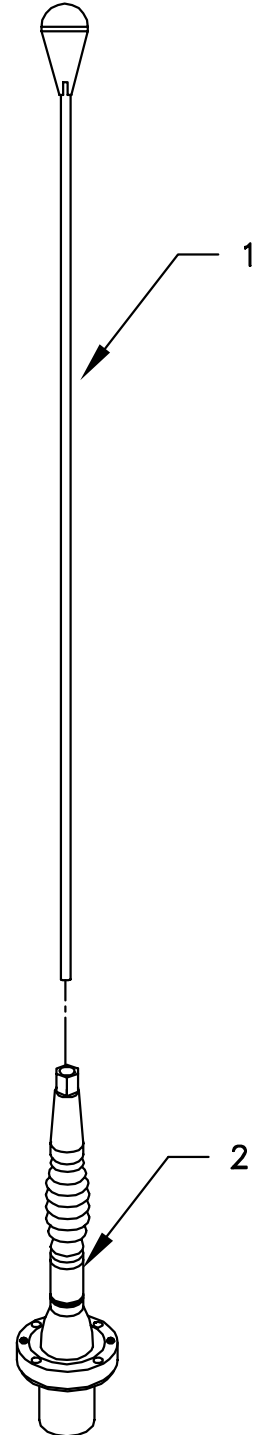
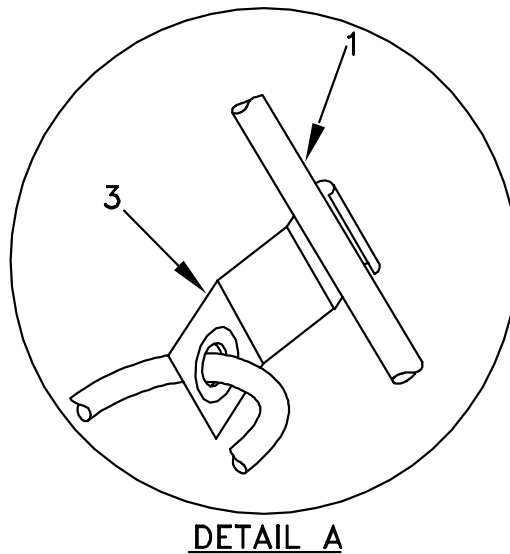

- 1. ANTENNA ELEMENT
- 2. ANTENNA BASE
- 3. WIRE ROPE ASSEMBLY

Figure 5-3. Top Antenna Assembly Installation

5.2 Installation of Mounting Base, Electrical Equipment MT-6352/VRC (mounting base). Remove and retain attaching bag of 5/16 in mounting hardware for installation. To insure good electrical grounding, any rust, corrosion or paint around mounting holes in radio shelf should be removed before installing the mounting base. See Figure 5-4 and perform the following steps to install the mounting bases.

ITEM	ACTION	REMARKS
NOTE		
Apply a thin coat of adhesive-sealant to both sides of each internal/external-toothed (IET) washer before it is installed, and to the area of contact where IET washer is to be placed.		
a. Mounting base (1) and existing radio shelf.	Remove a 2" square area of paint on the underside of the mounting base (1) around left front and rear mounting holes. Remove a 2" square area of paint on the existing radio shelf around the existing mounting holes that mate with the left front and rear mounting holes of mounting base (1). Clean the paint removed areas and apply a thin coat of conductive anti-seize compound.	Tools: Electric grinder or equivalent.
b. Mounting base (1).	Place on existing radio shelf over existing mounting holes. See Figure 5-4.	
c. Two outer thumbscrews (4).	Turn ccw until both sets of threads have cleared center of holes.	
d. Mounting base (1).	Align four holes and rear slot with matching hole pattern in shelf. See Figure 5-4.	
e. Five machine bolts (6), ten internal/external-toothed (IET) washers (3) and five nuts (2).	Install and tighten to mounting base (1) and shelf. See Figure 5-4.	Tools: 1/2 in socket and 1/2 in open/box wrench.
f. Two outer thumbscrews (4).	Tighten and secure to rim clenching clamps (5) and mounting base (1).	

5.2 Installation of Mounting Base, Electrical Equipment MT-6352/VRC (mounting base). Continued.

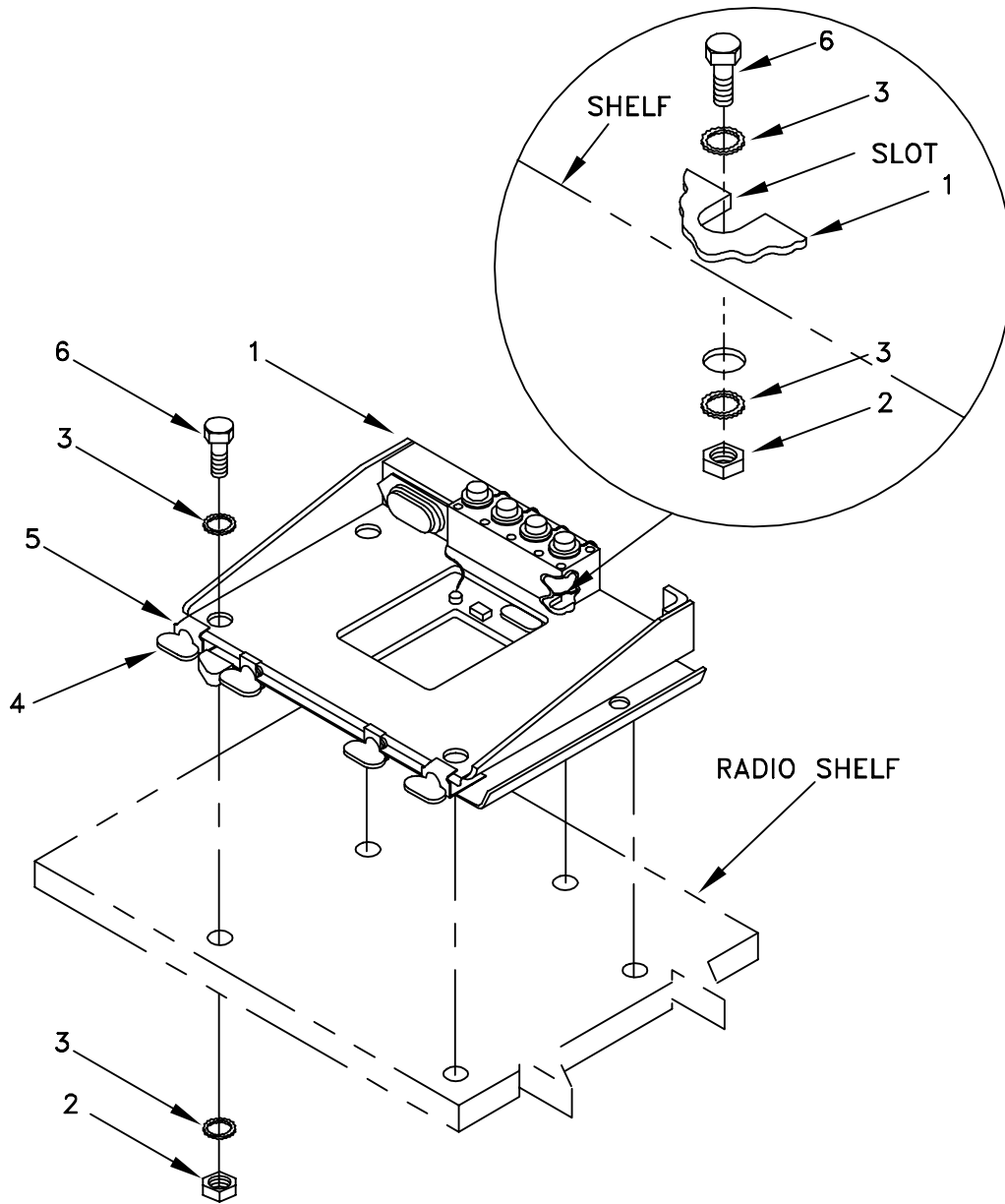

- 1. MOUNTING BASE
- 2. NUT (5/16-24 IN)
- 3. IET WASHER (5/16 IN)
- 4. THUMBSCREW
- 5. RIM CLENCHING CLAMP
- 6. MACHINE BOLT (5/16-24 x 1 IN)

Figure 5-4. Mounting Base Installation

5.3 Installation of Cables. To accomplish the installation, leave loop clamps and tiedown straps loose enough to adjust cable slack and allow easy adjustment of equipment. When installation is complete, tighten and secure all clamps, clips and tiedown straps.

WARNING

Make sure vehicle power source is positioned OFF or disconnected before installing cables.

ITEM	ACTION	REMARKS
a. Existing cable guard and mounting hardware.	Temporarily remove. See Figure 5-5 (1).	
b. Power cable (1) connector P1.	Insert through existing grommet at bottom of turret, below floorplate; then connect and secure to power distribution box connector P2.	
c. Power cable (1).	Route up turret wall along existing cable harness; then insert connector P2 through cable hole and position on lower level of radio shelf (behind commander's backrest). See Figures 5-5 (1) and 5-5 (2).	
d. Commander's backrest and existing mounting hardware.	Temporarily remove from front of radio shelf. See Figure 5-5 (2).	
e. Power cable (1) connector P2.	Position on top of mounting base (10).	
f. Existing loop clamp and mounting hardware (on lower level of radio shelf behind commander's seat).	Wrap clamp around power cable (1); then reinstall to existing boss. See Figure 5-5 (2) for location(s).	
g. Three tiedown straps (2).	Install loosely around power cable (1) and existing cable harness. See Figure 5-5 (1) for location(s).	
h. RF cable (8) connector P1.	Insert through installed loop clamp; then connect and secure to antenna base (9) connector J1. See Figure 5-5 (2).	
i. RF cable (8).	Route down and across rear turret wall to radio shelf.	
j. RF cable (8) connector P2.	Position on top of mounting base (10).	
k. RF cable (3) connector P1.	Insert through installed loop clamp; then connect and secure to antenna base (2) connector J1.	
l. RF cable (3).	Route across wall towards rear of turret.	

5.3 Installation of Cables. Continued

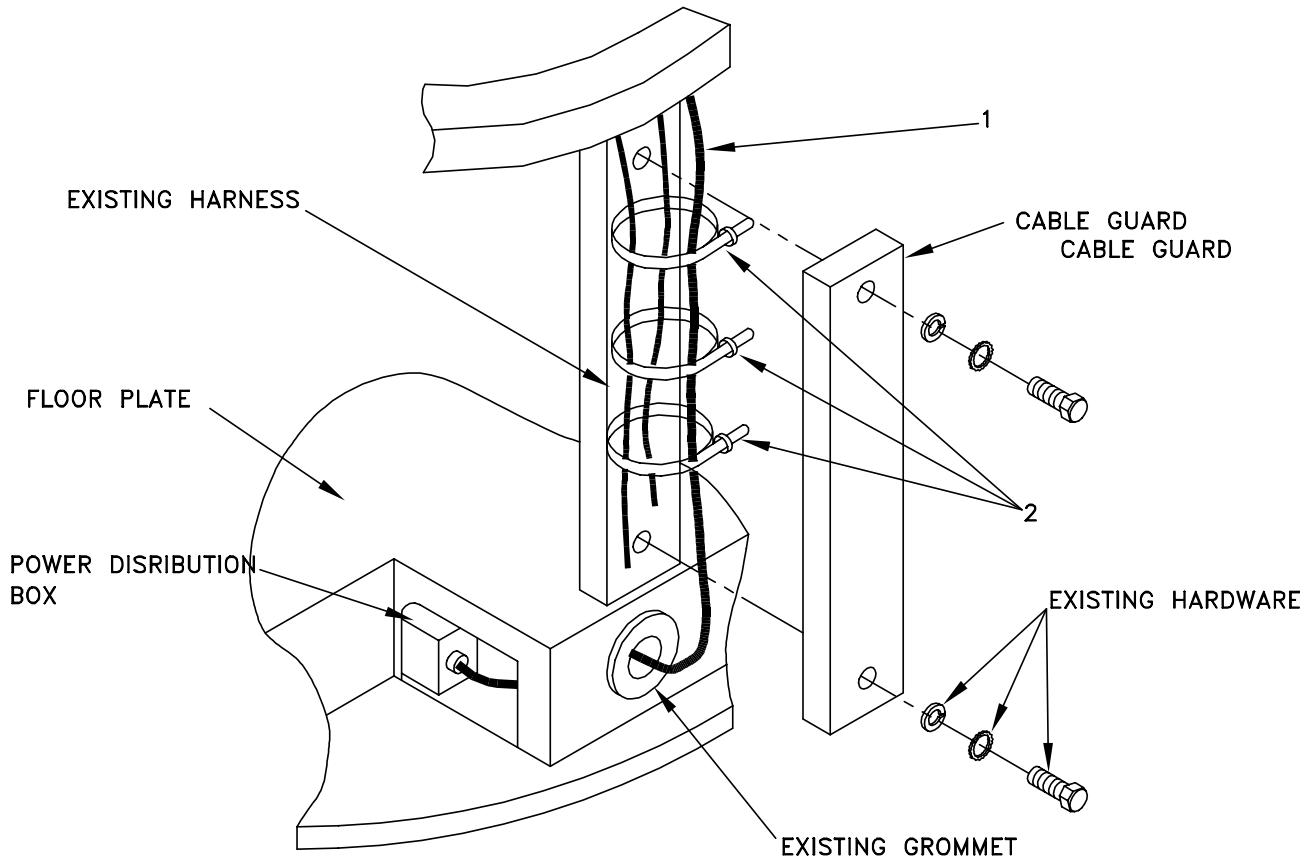

- 1. POWER CABLE, CX-13306/VRC (8FT, 0 IN)
- 2. TIEDOWN STRAP

Figure 5-5 (1). Cable Installation: Turret Doorway

5.3 Installation of Cables. Continued

ITEM	ACTION	REMARKS
m. Two loop clamps (5), one loop clamp (4), three pan-head machine screws (no 10-24 x 1/2 in.) and three lock washers (no. 10)	Wrap clamps around RF cable (3); then install to existing bosses on turret wall. See Figure 5-5 (2) for locations.	Tools: Phillips screwdriver.
n. Two loop clamps (6), two cap screws (1/4-20 x 1/2 in), and two lock washers (1/4 in)	Wrap clamps around RF cable (3); then install to existing bosses on turret wall.	Tools: 7/16 in socket.
o. RF cable (3) connector P2.	Position on top of mounting base (10).	
p. Loop clamp (7), pan-head machine screw (no. 10-24 x 1/2 in) and lock washer (no. 10)	Wrap around RF cable (3); then install to existing boss on turret wall. See Figure 5-5 (2) for location.	Tools: Phillips screwdriver.
q. Existing cable guard and mounting hardware (removed in step a.)	Reinstall and secure over power cable (1) and existing cable harness. See Figure 5-5 (1).	
r. Power cable (1).	Connect and secure to mounting base (10) connector J1.	
s. Commander's backrest and existing mounting hardware (removed in step d).	Reinstall. See Figure 5-5 (2).	
t. RF cable (1) connector P1.	Connect and secure to antenna base (2) connector J1. See Figure 5-5 (3).	
u. RF cable (1).	Route behind existing work light then insert through cable hole in box with existing wiring harness then upward along rear wall towards curbside wall; then route along existing cable harness on curbside wall and position connector P2 on mounting base (3). See Figure 5-5 (3).	
v. RF cable (4) connector P1.	Connect and secure to antenna base (5) connector J1. See Figure 5-5 (3).	
w. RF cable (4).	Route behind existing work light then insert through cable hole in box with existing wiring harness then route along existing cable harness on curbside wall and position connector P2 on top of MT-6353 (6). See Figures 5-5 (3).	
x. Existing power cable (5)	Connect and secure to mounting base (3) connector J1.	

5.3 Installation of Cables. Continued

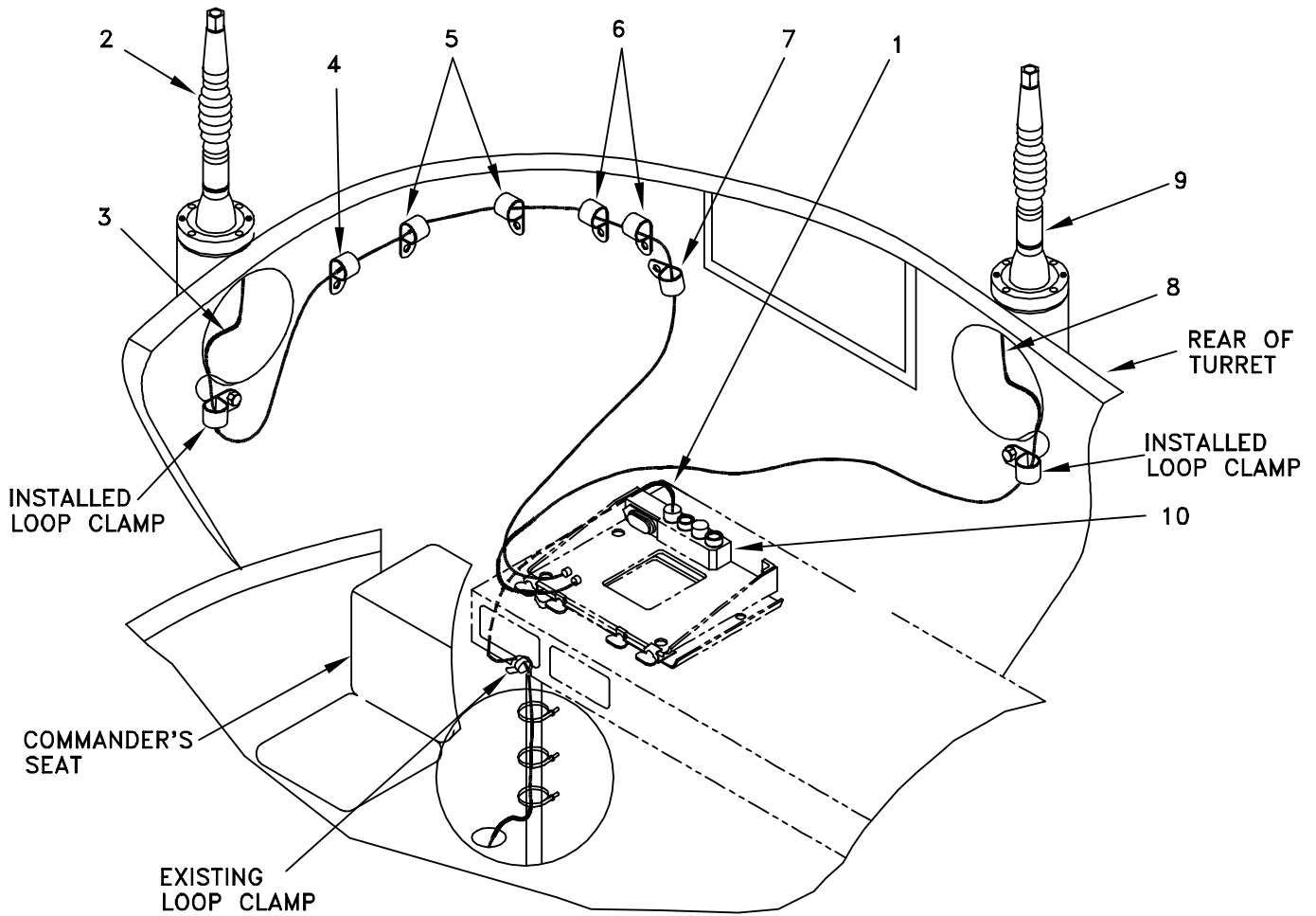

- 1. POWER CABLE CX-13306/VRC (8 FT, 0 IN)
- 2. ANTENNA BASE (SIDE)
- 3. RF CABLE, CG-3855/VRC (5 FT, 0 IN)
- 4. LOOP CLAMP (1/2-1/4 IN)
MACHINE SCREW (NO. 10-24 x 1/2 IN)
LOCK WASHER (NO. 10)
- 5. LOOP CLAMP (3/4-1/4 IN)
MACHINE SCREW (NO. 10-24 x 1/2 IN)
LOCK WASHER (NO. 10)
- 6. LOOP CLAMP (1/4-1/4 IN)
CAP SCREW (1/4-20 x 1/2 IN)
LOCK WASHER (1/4 IN)

- 7. LOOP CLAMP (1-1/4 IN)
MACHINE SCREW (NO. 10-24 x 1/2 IN)
LOCK WASHER (NO. 10)
- 8. RF CABLE, CG-3855/VRC (7 FT, 0 IN)
- 9. ANTENNA BASE (REAR)
- 10. MOUNTING BASE

Figure 5-5 (2). Cable Installation: Turret Interior

5.3 Installation of Cables. Continued

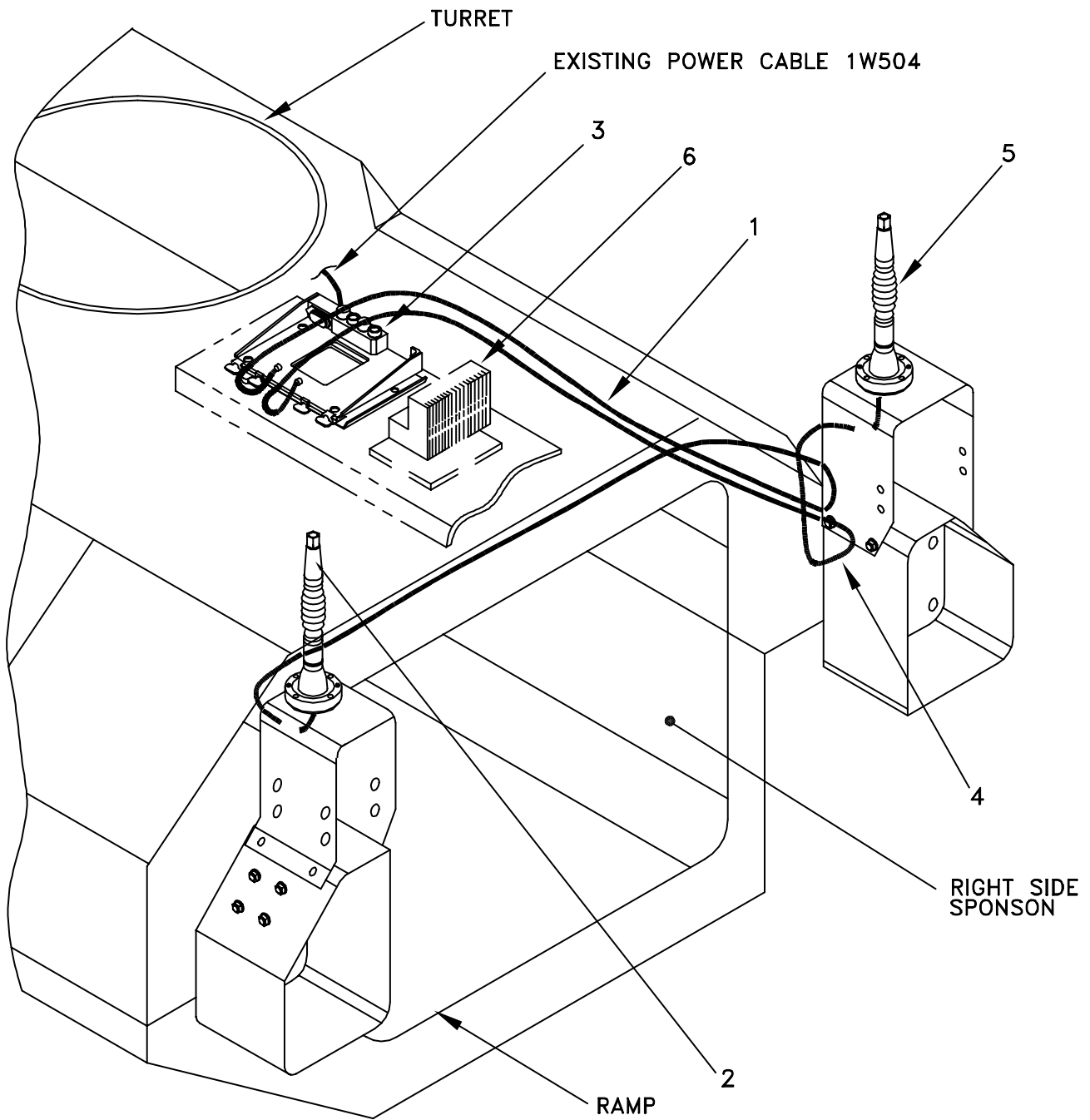

- 1. RF CABLE, CG-3855/VRC (18 FT, 0 IN)
- 2. ANTENNA BASE (ROADSIDE)
- 3. MOUNTING BASE
- 4. RF CABLE, CG-3855/VRC (12 FT, 0 IN)
- 5. ANTENNA BASE (CURBSIDE)
- 6. MT-6353/VRC

Figure 5-5 (3). Cable Installation: RF Cable Routing

5.4 Installation of Mounting Base, Electrical Equipment MT-6353/VRC. Use the following instructions to install MT-6353/VRC mounting base. Refer to Section 5.5 for connection of cables.

ITEM	ACTION	REMARKS
NOTE		
<p>Apply a thin coat of adhesive-sealant to both sides of each internal/external-toothed (IET) washer during installation, and to the area of contact where IET washer is to be placed. Before proceeding, connect and secure CX-13291/VRC control cable and existing power cable to MT-6353 mounting base. (Refer to Section 5.5, step b.)</p>		
<p>a. MT-6353/VRC mounting base (1).</p>	<p>Using MT-6353/VRC as template, mark and drill four 11/32 in diameter holes in radio shelf. See Figure 5-1 (3) for locations.</p>	<p>Tools: Electric drill and 11/32 in drill bit.</p>
<p>b. MT-6353/VRC mounting base (1) and existing radio shelf.</p>	<p>Remove a 2" square area of paint on the underside of MT-6353/VRC mounting base (1) around the front two mounting holes. Remove a 2" square area of paint on the existing radio shelf around the front two holes drilled in step a. Clean the paint removed areas and apply a thin coat of conductive anti-seize compound.</p>	<p>Tools: Electric grinder or equivalent.</p>
<p>c. MT-6353/VRC mounting base (1).</p>	<p>Align front holes and rear slots with matching hole pattern in radio shelf. See Figure 5-6.</p>	
<p>d. Two machine bolts (2), two IET washers (3) and nut strip (5).</p>	<p>Install and secure to rear slots in MT-6353/VRC mounting base (1) and radio shelf.</p>	<p>Tools: 1/2 in socket.</p>
<p>e. Two machine bolts (2), four IET washers (3) and two nuts (4).</p>	<p>Install and secure to front two holes in MT-6353/VRC mounting base (1) and radio shelf.</p>	<p>Tools: 1/2 in socket and 1/2 in open/box wrench.</p>

5.4 Installation of Mounting Base, Electrical Equipment MT-6353/VRC. Continued.

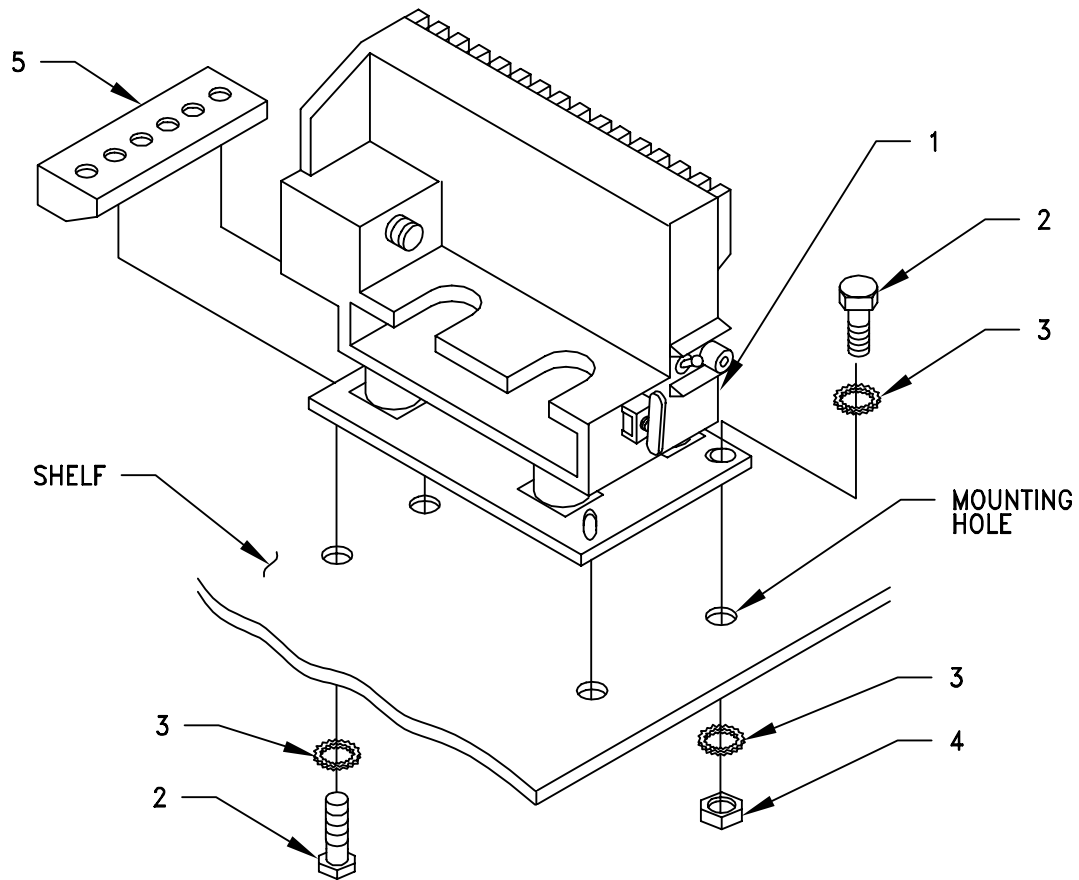

1. MOUNTING BASE
2. MACHINE BOLT (5/16-24 x 1 IN)
3. IET WASHER (5/16 IN)
4. NUT (5/16-24 IN)
5. NUT STRIP

Figure 5-6. MT-6353/VRC Mounting Base Installation

5.5 Post-Installation and Checkout. After equipment is installed and cables are connected, perform the following steps.

ITEM	ACTION	REMARKS
a. Equipment.	Check for secure mounting. Check for loose parts, connectors, and mounting hardware.	
b. Cables.	Check for proper installation and connection of cables. See Figure 5-7 for cable connections. Unused cables should be stowed in appropriate place inside the vehicle.	
c. Loop clamps.	Check that all have been properly installed and tightened.	
d. Protective covers.	Insure that all installed cables are covered when not in use or connected.	
e. Radio issued with vehicle.	Install and connect cables. See TM 11-5820-890-20-1 or TM 11-5820-890-20-4 for installation and operational (OP) checks and instructions.	
f. MK line replaceable units.	See TM 11-5820-890-20P for Repair Parts and Special Tools List (RPSTL) information.	

5.5 Post-Installation and Checkout. Continued.

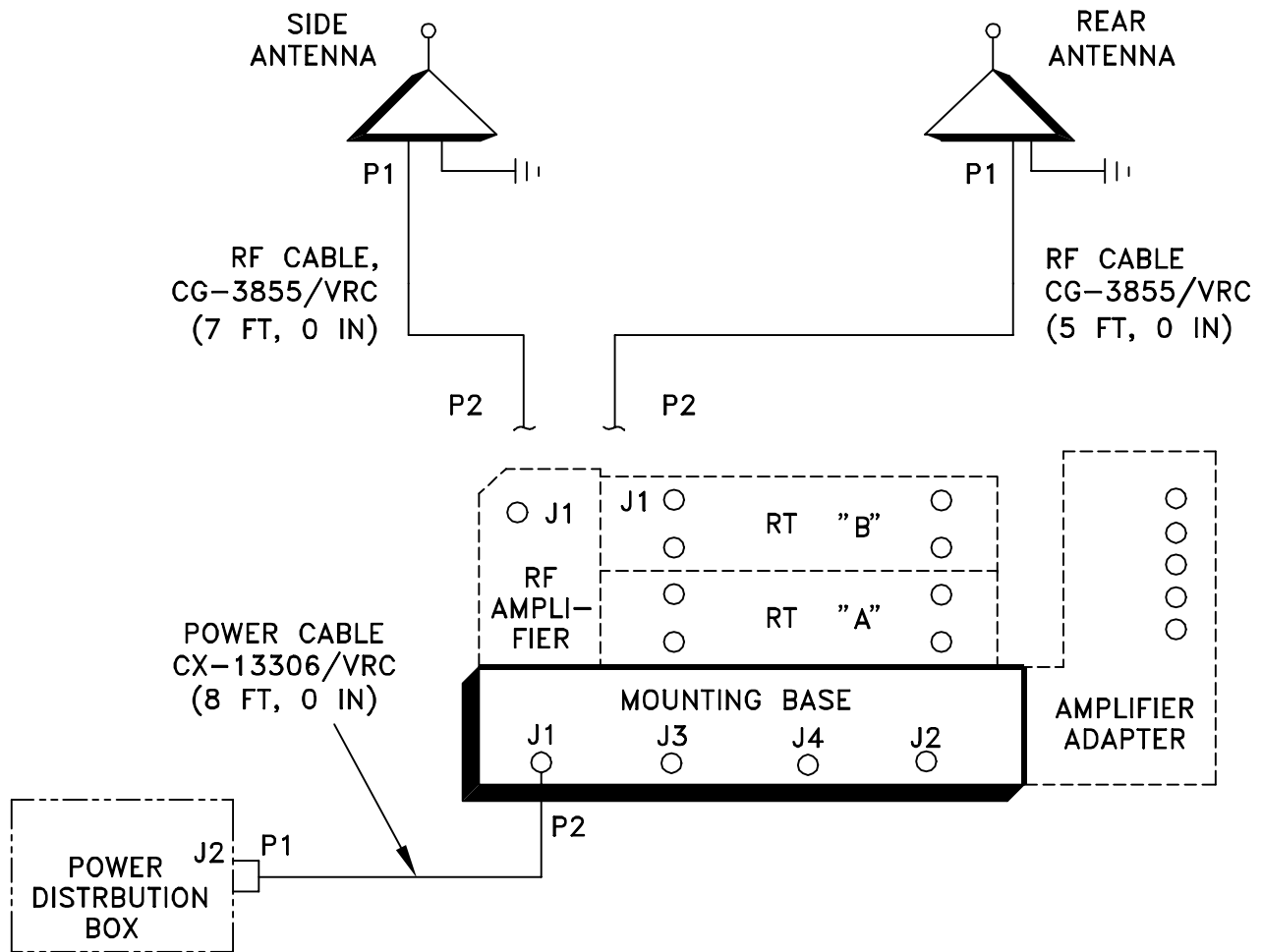

CABLE ASSEMBLY	FROM			TO		
	CABLE CONN.	UNIT	UNIT CONN.	CABLE CONN.	UNIT	UNIT CONN.
CX-13306/VRC (8 FT, 0 IN)	P2	Mounting base (turret)	J1	P1	Power distribution box	
CG-3855/VRC (5 FT, 0 IN)	P2	RT "B" (turret)	J1	P1	Antenna base (side)	J1
CG-3855/VRC (7 FT, 0 IN)	P2	RF amplifier (turret)	J1	P2	Antenna base (rear turret)	J1

Figure 5-7 (1). Cable Diagram: For AN/VRC-91 Series

5.5 Post-Installation and Checkout. Continued.

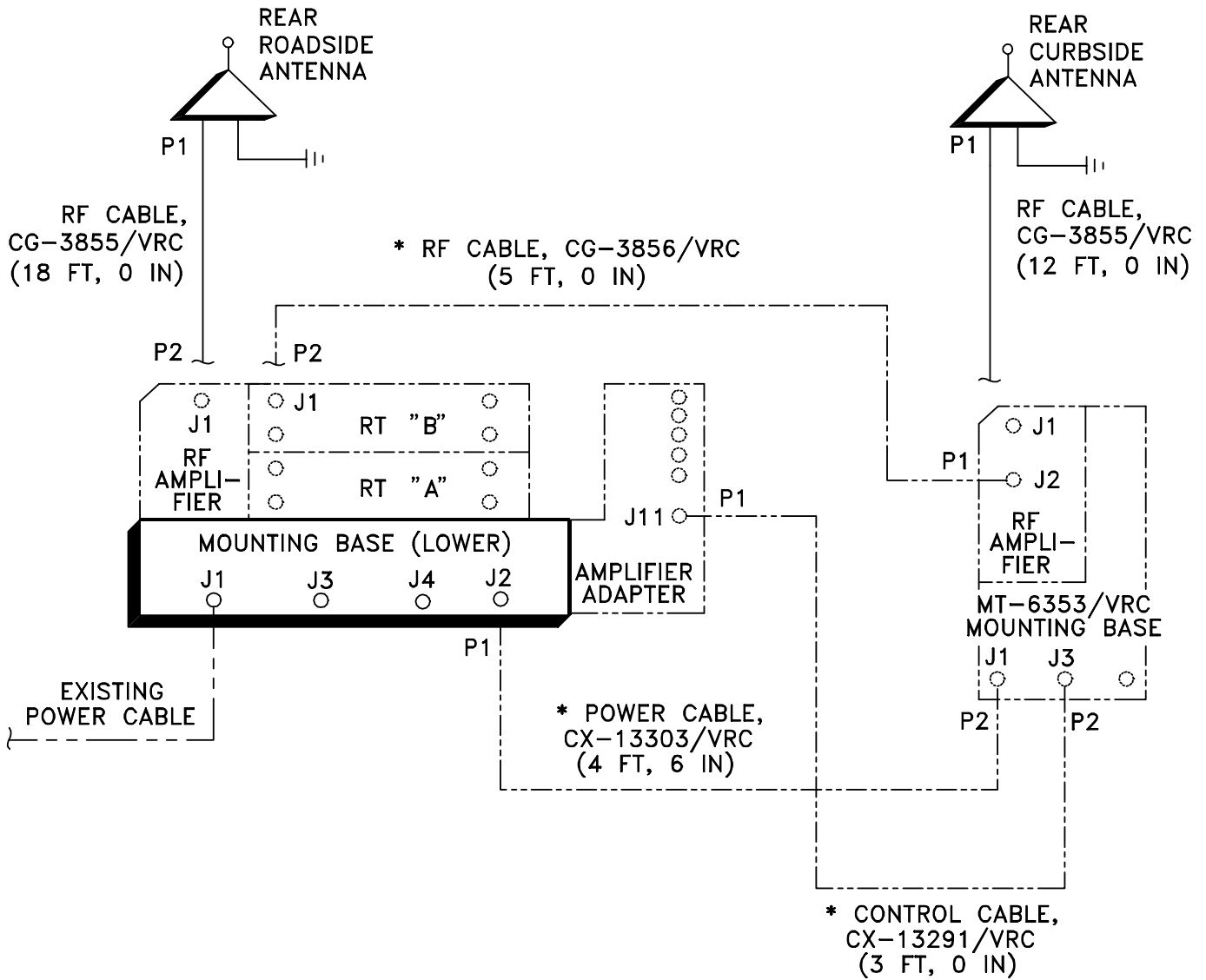

* NOT SUPPLIED IN THIS MK.

Figure 5-7 (2). Cable Diagram: For AN/VRC-92 Series

5.5 Post-Installation and Checkout. Continued.

CABLE ASSEMBLY	FROM			TO		
	CABLE CONN.	UNIT	UNIT CONN.	CABLE CONN.	UNIT	UNIT CONN.
CG-3855/VRC (18 FT, 0 IN)	P1	Antenna base (roadside rear)	J1	P2	MT-6353/VRC (RF amplifier)	J1
CG-3855/VRC (12 FT, 0 IN)	P1	Antenna base (curbside rear)	J1	P2	RF amplifier (hull)	J1
*CX-13303/VRC (4 FT, 6 IN)	P1	Mounting base	J2	P2	MT-6353/VRC mounting base	J1
*CX-13291/VRC (3 FT, 0 IN)	P1	Amplifier adapter	J11	P2	MT-6353/VRC mounting base	J3
*CG-3856/VRC (5 FT, 0 IN)	P1	MT-6353/VRC RF amplifier	J2	P2	RT "B" (hull)	J1

* Not supplied in this MK.

Figure 5-7 (2). Cable Diagram: For AN/VRC-92 Series. Continued.

THIS PAGE INTENTIONALLY BLANK

APPENDIX A

REFERENCES

DA PAM 25-30	Consolidated Index of Army Publications and Blank Forms (Contained on EM 0001)
DA PAM 710-2-1	Using Unit Supply System Manual Procedures as Contained in Unit Supply UPDATE
EM 0071	Radio, SINCGARS, Ground/Airborne
SB 11-131-2	Vehicular Radio Sets and Authorized Installations (SINCGARS)
TM 11-5820-890-10-1	Operator's Manual (ICOM Radio Sets) (Included in EM 0071)
TM 11-5820-890-10-3	Operator's Manual (Non-ICOM Radio Sets) (Included in EM 0071)
TM 11-5820-890-10-8	Operator's Manual (ASIP Radio Sets) (Included in EM 0071)
TM 11-5820-890-20-1	Unit Maintenance Manual (ICOM Radio Sets, Vol. 1) (Included in EM 0071)
TM 11-5820-890-20-2	Unit Maintenance Manual (ICOM Radio Sets, Vol. 2) (Included in EM 0071)
TM 11-5820-890-20-3	Unit Maintenance Manual Handbook (ICOM Radio Sets) (Included in EM 0071)
TM 11-5820-890-20P	Repair Parts and Special Tools List (Included in EM 0071)

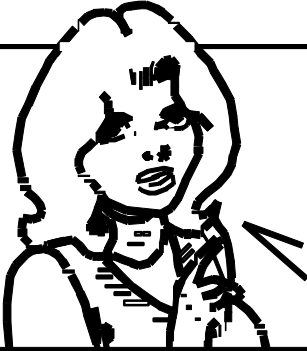

THEN ... JOT DOWN THE INFO ABOUT IT ON THIS FORM. CAREFULLY TEAR IT OUT. FOLD IT AND DROP IT IN THE MAIL.

SOMETHING WRONG WITH THIS PUBLICATION

FROM: (PRINT YOUR UNIT'S COMPLETE ADDRESS)
 Commander
 Stateside Army Depot
 ATTN: AMSTA-US
 Stateside, N.J. 07703-5007

DATE SENT
 10 July 1975

PUBLICATION NUMBER TM 11-5840-340-20	PUBLICATION DATE 23 Jan 74	PUBLICATION TITLE Radar Set AN/PRC-76
---	-------------------------------	--

BE EXACT PIN-POINT WHERE IT IS				IN THIS SPACE TELL WHAT IS WRONG AND WHAT SHOULD BE DONE ABOUT IT:
PAGE NO	PARA GRAPH	FIGURE NO	TABLE NO	
2-25	2-28			<p>Recommend that the installation antenna alignment procedure be changed throughout to specify a 20 IFF antenna lag rather than 10.</p> <p>REASON: Experience has shown that with only a 10 lag, the antenna servo system is too sensitive to wind gusting in excess of 25 knots, and has a tendency to rapidly accelerate and decelerate as it hunts, causing strain to the drive train. Hunting is minimized by adjusting the lag to 20 without degradation of operation.</p>
3-10	3-3		3-1	<p>Item 5, Functional column. Change • 2 dB" to • 3 dB".</p> <p>REASON: The adjustment procedure for the TRANS POWER FAULT indicator calls for a 3 dB (500 watts) adjustment to light the TRANS POWER FAULT indicator.</p>
5-6	5-8			<p>Add new step f.1 to read, • Replace cover plate removed in step f.1, above."</p> <p>REASON: To replace the cover plate.</p>
		FO-3		<p>Zone C 3. On J1-2, change • +24 VDC" to • +5 VDC".</p> <p>REASON: This is the output line of the 5 VDC power supply. +24 VDC is the input voltage.</p>

TEAR ALONG DOTTED LINE

PRINTED NAME, GRADE OR TITLE AND TELEPHONE NUMBER SSG I. M. DeSpirito 999-1776	SIGN HERE
---	---------------

FILL IN YOUR
UNIT'S ADDRESS

FOLD BACK

DEPARTMENT OF THE ARMY

OFFICIAL BUSINESS

PLEASE
AFFIX
STAMP
POSTAGE
REQUIRED

SAMPLE

Commander
U.S. Army Communications-Electronics Command
and Fort Monmouth
ATTN: AMSEL-LC-LEO-D-CS-CFO
Fort Monmouth, New Jersey 07703-5006

TEAR ALONG DOTTED LINE

SOMETHING WRONG WITH THIS PUBLICATION



THEN ... JOT DOWN THE INFO ABOUT IT ON THIS FORM. CAREFULLY TEAR IT OUT. FOLD IT AND DROP IT IN THE MAIL.

FROM: (PRINT YOUR UNIT'S COMPLETE ADDRESS)

DATE SENT

PUBLICATION NUMBER

PUBLICATION DATE

PUBLICATION TITLE

BE EXACT PIN-POINT WHERE IT IS

IN THIS SPACE TELL WHAT IS WRONG AND WHAT SHOULD BE DONE ABOUT IT:

PAGE NO

PARA GRAPH

FIGURE NO

TABLE NO

TEAR ALONG DOTTED LINE

PRINTED NAME, GRADE OR TITLE AND TELEPHONE NUMBER

SIGN HERE

FILL IN YOUR
UNIT'S ADDRESS

FOLD BACK

DEPARTMENT OF THE ARMY



OFFICIAL BUSINESS

PLEASE
AFFIX
STAMP
POSTAGE
REQUIRED

TEAR ALONG DOTTED LINE

Commander
U.S. Army Communications-Electronics Command
and Fort Monmouth
ATTN: AMSEL-LC-LEO-D-CS-CFO
Fort Monmouth, New Jersey 07703-5006

SOMETHING WRONG WITH THIS PUBLICATION



THEN ... JOT DOWN THE INFO ABOUT IT ON THIS FORM. CAREFULLY TEAR IT OUT. FOLD IT AND DROP IT IN THE MAIL.

FROM: (PRINT YOUR UNIT'S COMPLETE ADDRESS)

DATE SENT

PUBLICATION NUMBER

PUBLICATION DATE

PUBLICATION TITLE

BE EXACT PIN-POINT WHERE IT IS

IN THIS SPACE TELL WHAT IS WRONG AND WHAT SHOULD BE DONE ABOUT IT:

PAGE NO

PARA GRAPH

FIGURE NO

TABLE NO

TEAR ALONG DOTTED LINE

PRINTED NAME, GRADE OR TITLE AND TELEPHONE NUMBER

SIGN HERE

FILL IN YOUR
UNIT'S ADDRESS

FOLD BACK

DEPARTMENT OF THE ARMY

OFFICIAL BUSINESS

PLEASE
AFFIX
STAMP
POSTAGE
REQUIRED

TEAR ALONG DOTTED LINE

Commander
U.S. Army Communications-Electronics Command
and Fort Monmouth
ATTN: AMSEL-LC-LEO-D-CS-CFO
Fort Monmouth, New Jersey 07703-5006

SOMETHING WRONG WITH THIS PUBLICATION

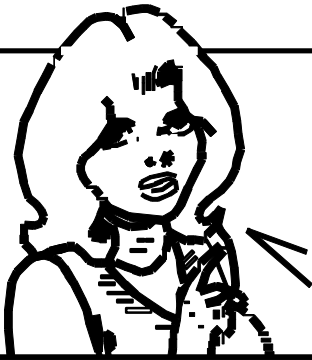

THEN ... JOT DOWN THE INFO ABOUT IT ON THIS FORM. CAREFULLY TEAR IT OUT. FOLD IT AND DROP IT IN THE MAIL.

FROM: (PRINT YOUR UNIT'S COMPLETE ADDRESS)

DATE SENT

PUBLICATION NUMBER

PUBLICATION DATE

PUBLICATION TITLE

BE EXACT PIN-POINT WHERE IT IS

IN THIS SPACE TELL WHAT IS WRONG AND WHAT SHOULD BE DONE ABOUT IT:

PAGE NO

PARA GRAPH

FIGURE NO

TABLE NO

TEAR ALONG DOTTED LINE

PRINTED NAME, GRADE OR TITLE AND TELEPHONE NUMBER

SIGN HERE

FILL IN YOUR
UNIT'S ADDRESS

FOLD BACK

DEPARTMENT OF THE ARMY

OFFICIAL BUSINESS

PLEASE
AFFIX
STAMP
POSTAGE
REQUIRED

**Commander
U.S. Army Communications-Electronics Command
and Fort Monmouth
ATTN: AMSEL-LC-LEO-D-CS-CFO
Fort Monmouth, New Jersey 07703-5006**

TEAR ALONG DOTTED LINE

By Order of the Secretary of the Army:

Official:

PETER J. SCHOOMAKER
General, United States Army
Chief of Staff

JOEL B. HUDSON
Administrative Assistant to the
Secretary of the Army
0400809

DISTRIBUTION:

To be distributed in accordance with the initial distribution number (IDN) 362144 requirements for TB 11-5820-890-20-115.

PIN: 080084-000